

ROOF PROJECTION FLASHING DETAILS

Figure 14a: Skylight Flashing

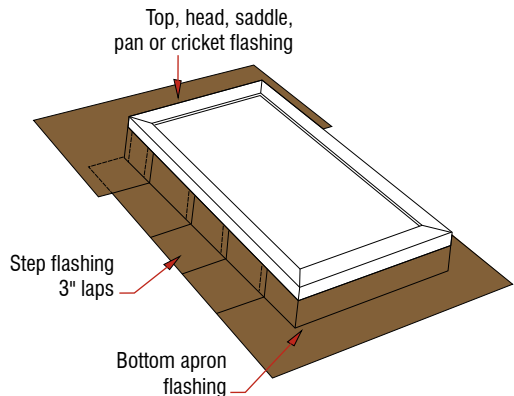

Figure 14b: Skylight Installation

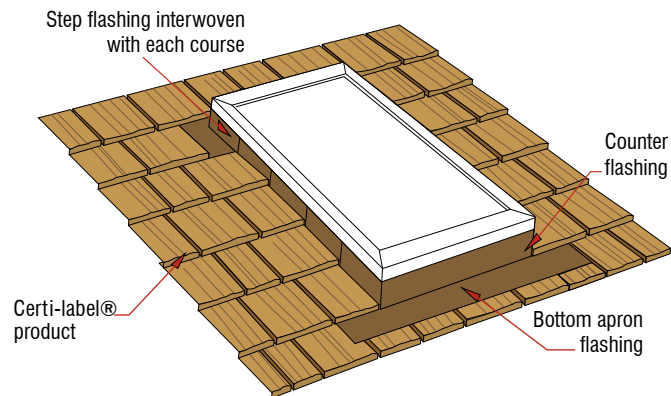
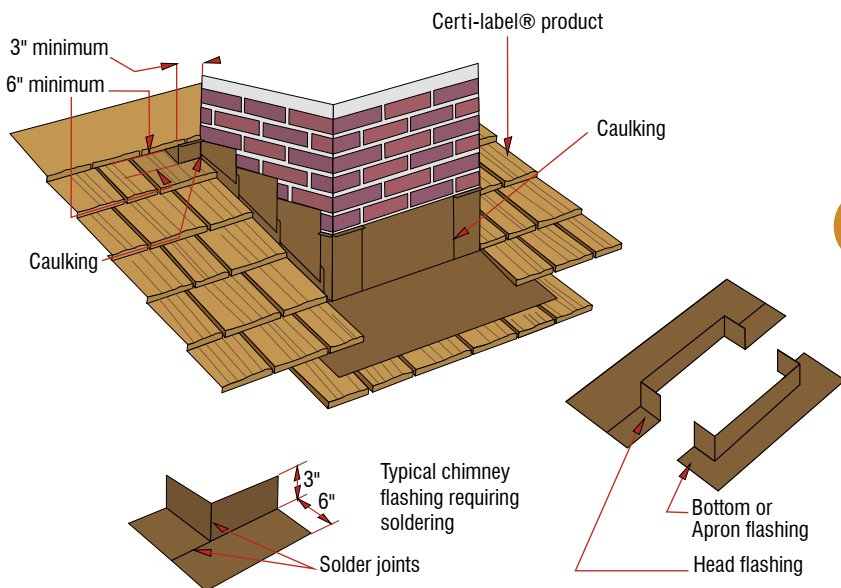

Figure 14c: Typical Projection Flashing



Recommended Step Flashing Width		
	Shakes	Shingles
Horizontal Width	4"	2 1/2"
Vertical Width	3"	2 1/2"



NOTE:

- Check with your local building code official for minimum gauge/thickness requirement and step-flashing height.

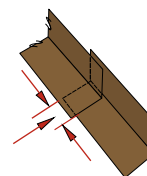

Typical chimney flashing not requiring soldering
Step flashing 3" minimum overlap

Figure 14d: Typical Projection Flashing

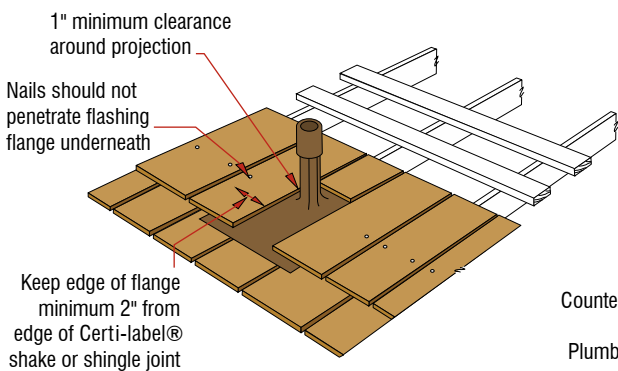
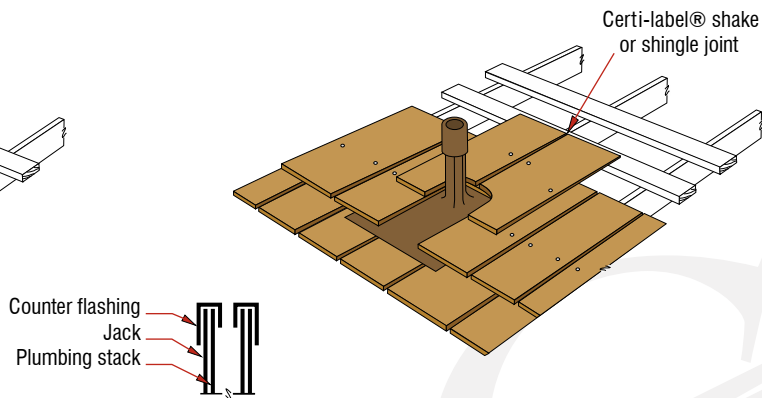

Figure 14e: Typical Projection Flashing



Figures 14a-14e: Flashing Details for Typical Roof Projections