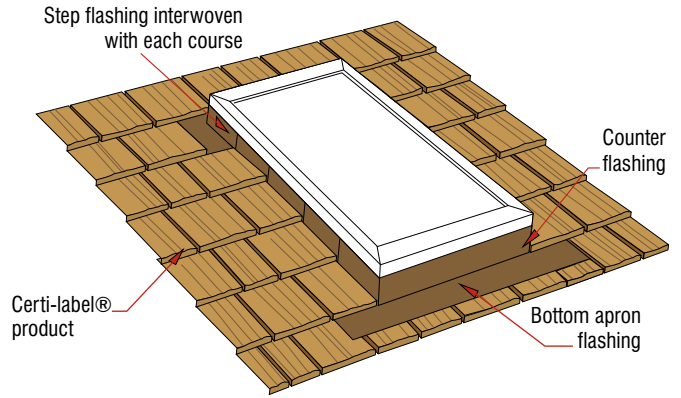
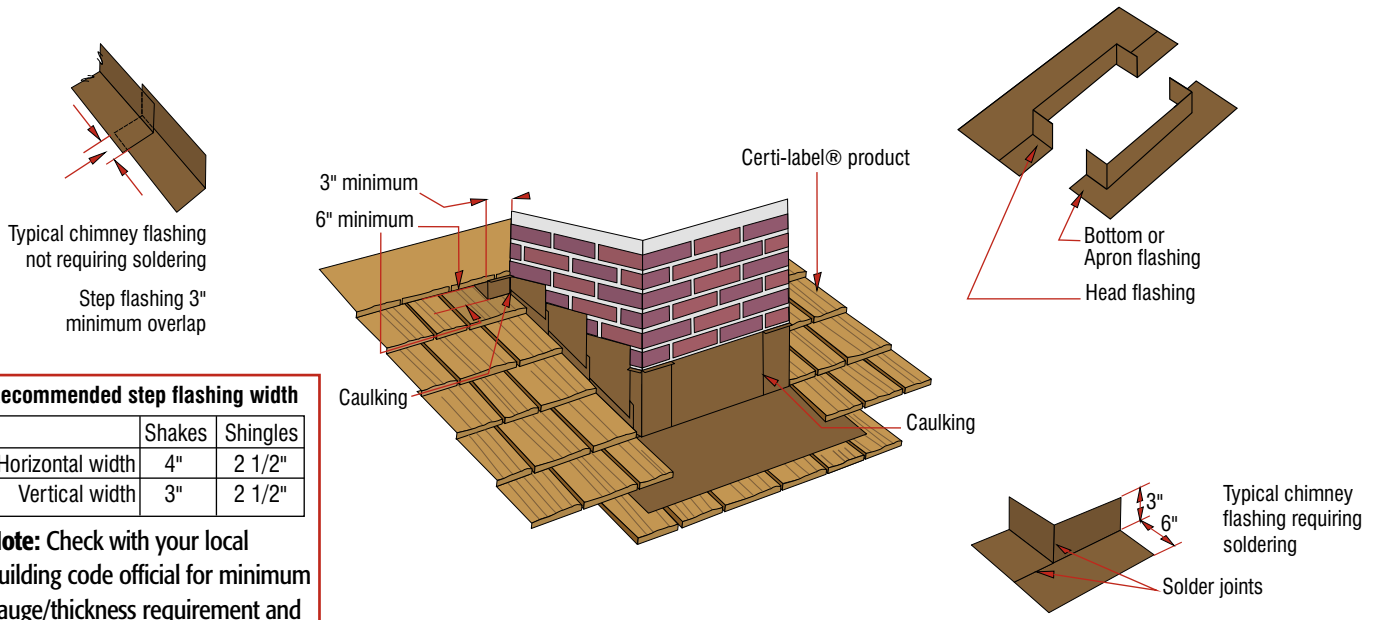

**Figure 14a: Skylight Flashing**



**Figure 14b: Skylight Installation**

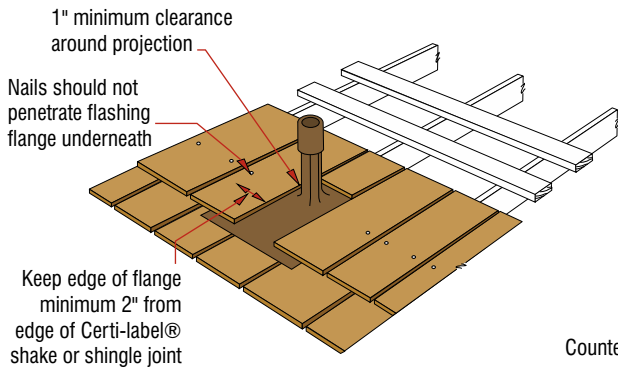

**Figure 14c: Typical Projection Flashing**

**Recommended step flashing width**

	Shakes	Shingles
Horizontal width	4"	2 1/2"
Vertical width	3"	2 1/2"

**Note:** Check with your local building code official for minimum gauge/thickness requirement and step-flashing height.



**Figure 14d: Typical Projection Flashing**

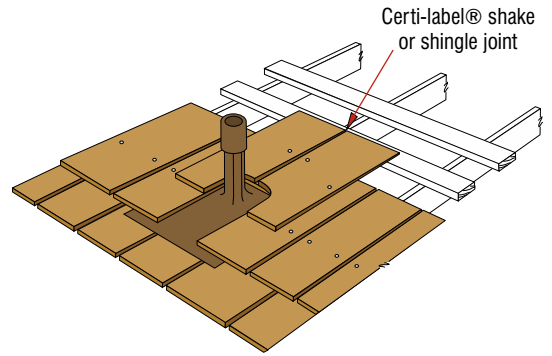

**Figure 14e: Typical Projection Flashing**

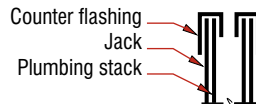

## Figures 14a-14e: Flashing Details for Typical Roof Projections

Check with building code official for local jurisdiction requirements